

# BUILD IT

## Final Challenge NXT Questions

Name: \_\_\_\_\_

Date: \_\_\_\_\_

1. Consider the following part of a program, which contains variables:

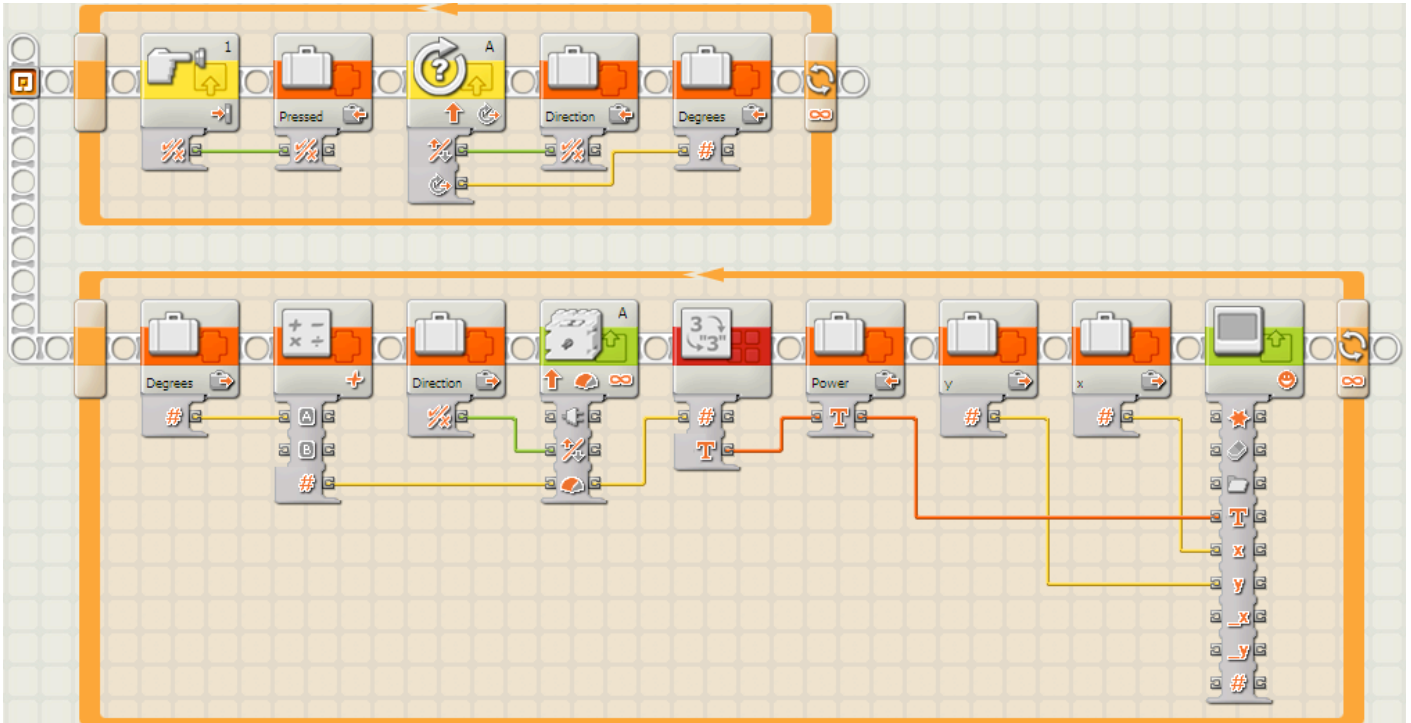

For each variable name below, circle the type of data it holds.

Variable Name

Data Type

x

Logic

Number

Text

y

Logic

Number

Text

*Pressed*

Logic

Number

Text

*Direction*

Logic

Number

Text

*Degrees*

Logic

Number

Text

*Power*

Logic

Number

Text

2. In the program segment below, a variable is read, its value is put through four different calculations (addition, subtraction, multiplication, and division) using math blocks, and then the new value is put in a new variable.

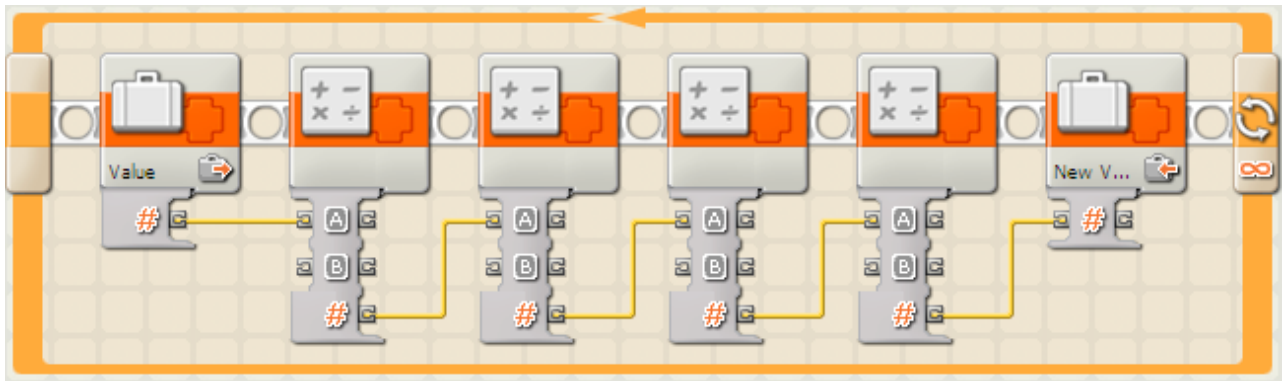

If the old value was 5, and the new value is 87, what must the control panels of the four math blocks look like? Look at the control panels below. Four of them are the ones used in this program, and the others are not. Identify which ones are the correct ones as well as the order, and number them 1 through 4. Cross out the ones that don't belong.

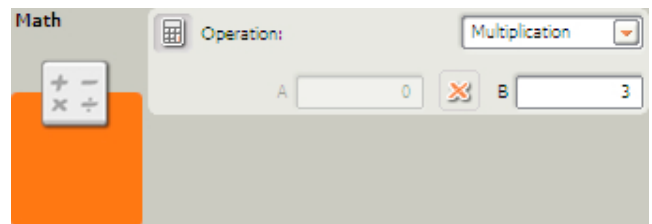
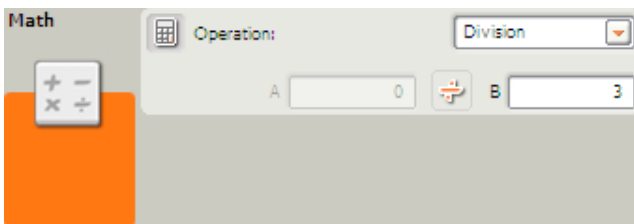
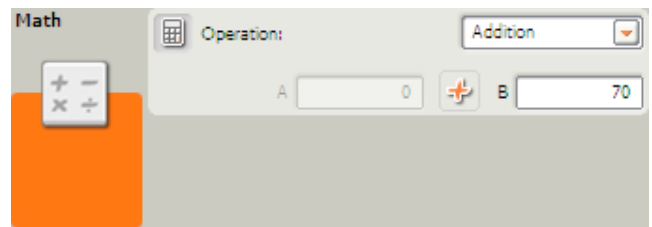
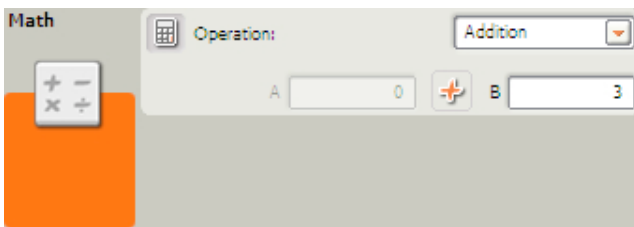
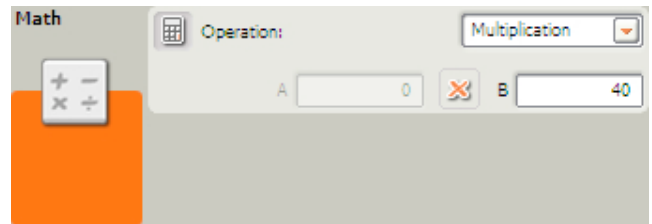
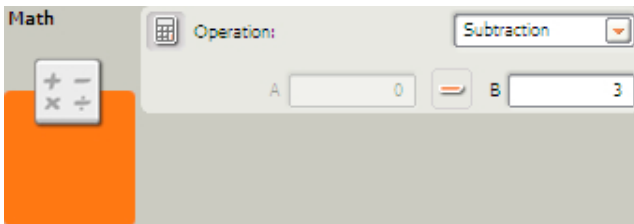
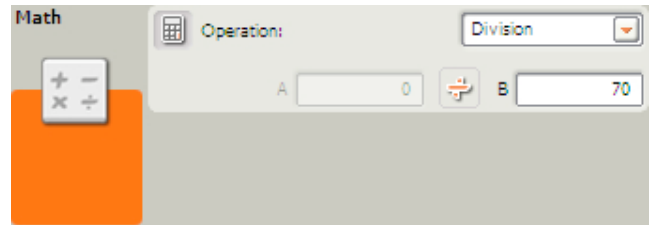
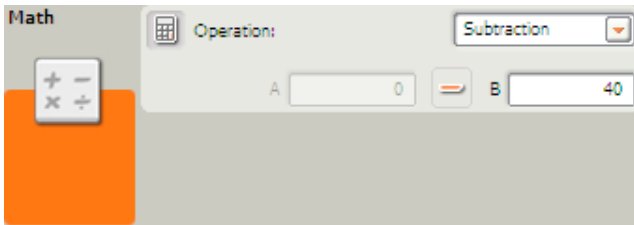

3. The two pictures below are from the same program. The switch is not in “flat” view, so two pictures were needed to show what each branch of the switch looks like.

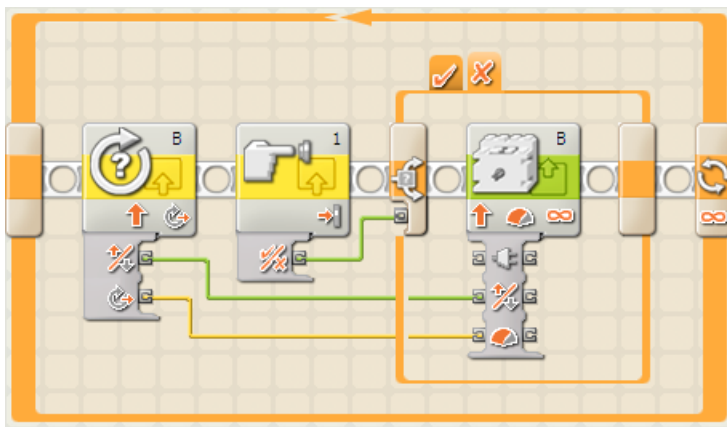
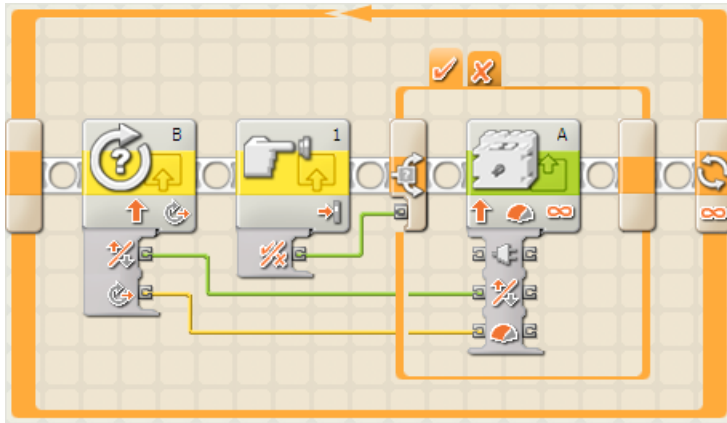

What does this program do?

4. Consider the following program:

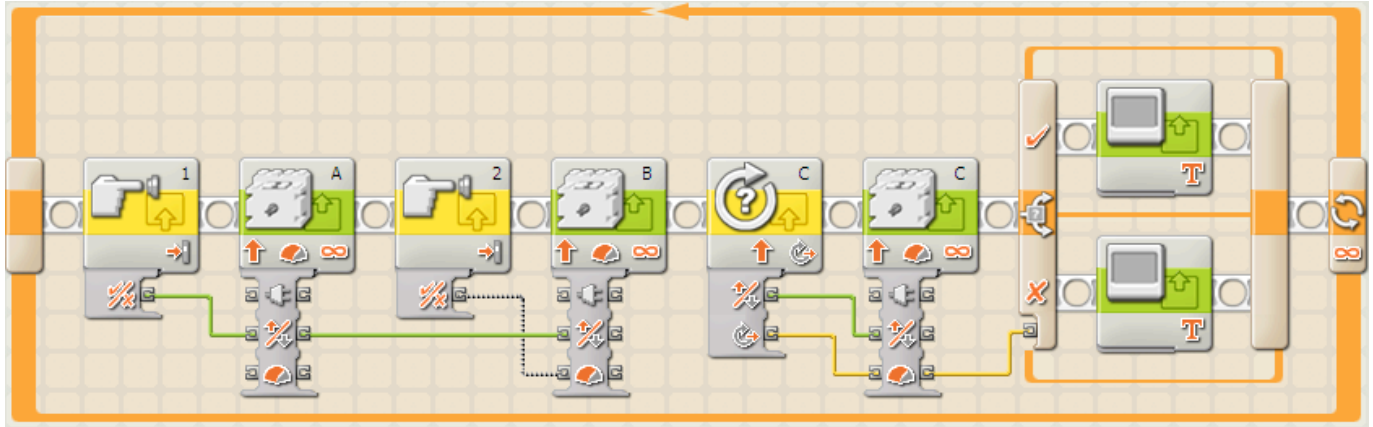

The program should work like this:

- When touch sensor 1 is pressed, the left propeller (controlled by motor A) should push forward. If it released, the left propeller should push backwards.
- When touch sensor 2 is pressed, the right propeller (controlled by motor B) should push forward. If it released, the right propeller should push backwards.
- Rotation sensor C should directly control both the direction and power of the vertical propeller, which is run by motor C.
- If the boat goes up, the screen should display “UP!”. If it goes down, then the screen should display “DOWN!”.

There are 3 bugs in the picture that need to be fixed. Circle each bug, put a number next to it (1, 2, or 3), and describe the bug and what would fix it below.

Bug Number	Description and Fix
(1)	
(2)	
(3)	